

Contactorless Brake Module

Manual

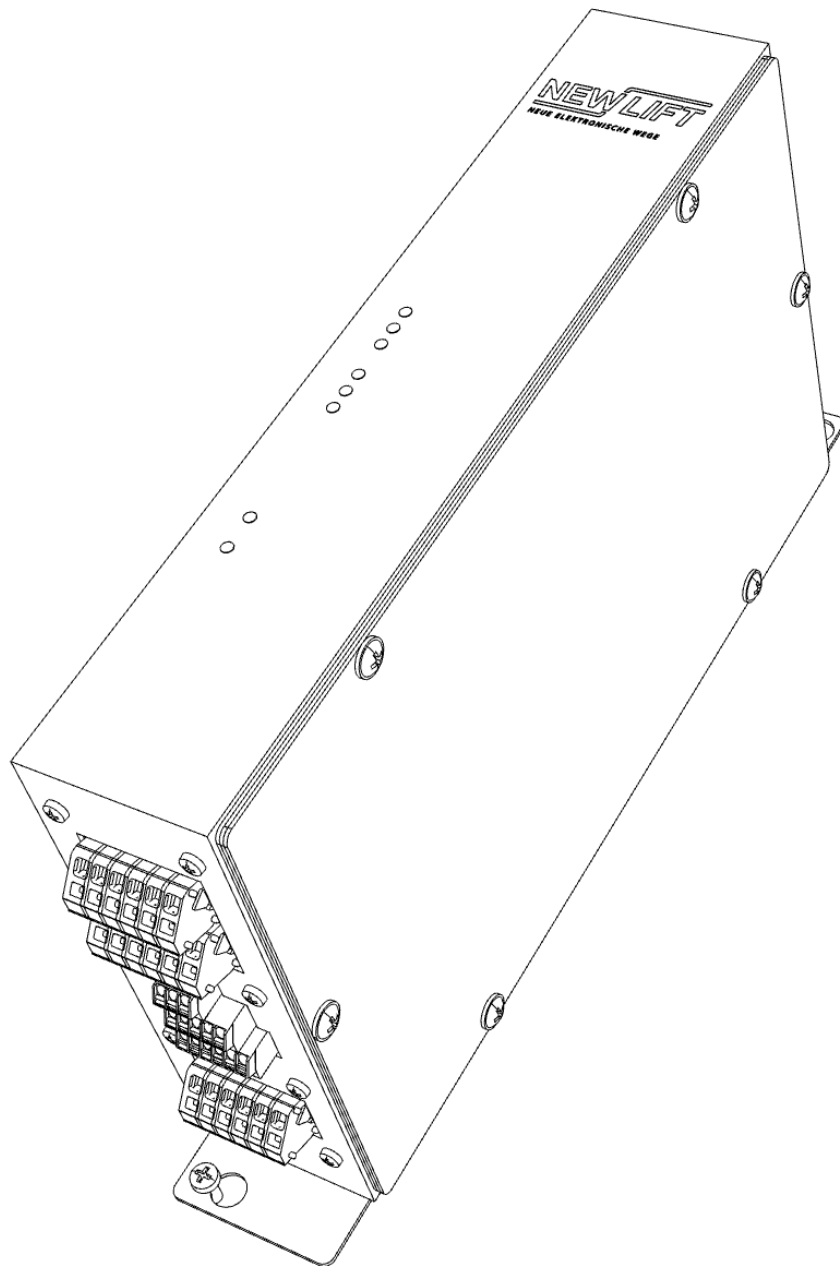

Manufacturer NEW *LIFT* Service Center GmbH
Ruwerstraße 16
54427 Kell am See

Tel: +49 6589 – 919 540
Fax: +49 6589 – 919 540 300
Mail: info@newlift-sc.de

www.newlift.de

Service line Tel: +49 6589 – 919 540
Mail: service@newlift-sc.de

First edition 30.10.2018

Author JW

Last change 23.11.2018

Release

Hardware version EF336.9, EF337.5, EF341.1

Software version V1.7.0.0

Doc. No. hb_cbm_2018-10_en_v1.2

Copyright © NEW *LIFT* Service Center GmbH, 2018.

This manual is protected by copyright. All rights, including those of copying, of reproduction, of translation and of modification, in whole or in part, are reserved by the publisher.

No part of this description may be reproduced in any form or copied with an electronic replication system without written permission.

Although great care has been taken in the production of texts and figures, we cannot be held legally liable for possible mistakes and their consequences.

Content

1.	About this manual.....	5
1.1	General.....	5
1.2	Abbreviations, characters and symbols used	5
1.3	Further information	5
1.4	How to contact us.....	5
2.	General safety regulations.....	6
2.1	Qualifications of the installing engineer	6
2.2	Residual dangers	7
2.3	Safety regulations.....	8
3.	Terminals.....	10
3.1	Pinout	11
4.	I/O-Modus.....	12
4.1	Configuration with dip switches	12
4.2	Brake coils with different voltages	13
4.3	Explanation of inputs	14
4.3.1	DRIVE-Signal.....	14
4.3.2	BRAKE-Signal	14
4.3.3	EVAK-Signal.....	14
4.3.4	Test-Signal.....	14
4.4	Explanation of Outputs	14
4.4.1	OK-Signal	14
4.4.2	Open-Signal.....	14
4.4.3	Test-Signal.....	14
4.5	Sequence of the control.....	15
4.5.1	Normal ride	15
4.5.2	Emergency stop.....	15
4.5.3	Brake test	15
4.5.4	Evacuation.....	15
5.	CANopen-Mode.....	16
6.	LEDs.....	17
6.1	Voltage setting.....	17
6.2	Status-LEDs	18
6.2.1	Status Monitoring.....	18
6.2.2	Status Controlling	18
7.	Technical data	20

Version History:

Version	Date	Remarks
1.0	31.10.2018	First version
1.1	06.11.2018 09.11.2018	5 Changed CANopen chapter 6.2.1 Error list extended by monitor CPU
1.2	23.11.2018	4.1 times for evacuation changed 4.3 Explanation of Inputs revised 4.4 Explanation of Outputs revised 4.5 Sequence of the control revised 4.6 EEPROM inserted

1. About this manual

1.1 General

The CBM Handbook is a comprehensive reference work for the experienced elevator expert.

Objectives of this manual:

- Describe the technical data of the CBM
- Describe the operation of the CBM
- Describe the configuration of the CBM
- Describe the messages of the CBM

The CBM is a module that can control brake coils of all voltages (40-200VDC) and currents (up to 4A) up to a power of 240VA without protection. It is type-tested according to DIN EN81-20. In addition, it can perform brake test and evacuation (for machine roomless systems). In addition, other functions are available, such as the connection of a motor PTC or brake monitoring. The function of the brake circuits is monitored by a continuous current measurement.

1.2 Abbreviations, characters and symbols used

CBM

Contactless Brake Module for elevators

DRIVE

Driving signal from the end of the safety chain

BRAKE

Brake signal to open the brake

EVAK

Evacuation signal for evacuation in the event of a fault in the system

TEST

Test signals for brake test

CANopen

CAN interface with CANopen protocol according to CiA Standard Draft 301

1.3 Further information

For integration with FST see the manual of the FST.

1.4 How to contact us

If, after referring to this manual, you still require assistance, our service line is there for you:

Tel: +49 6589 919 540

Mail: service@newlift-sc.de

Mon-Thurs: 8:00 a.m. – 12:00 p.m. and 1:00 p.m. – 5:00 p.m.

Fr: 8:00 a.m. – 3:00 p.m.

2. General safety regulations

All important safety regulations are summarized in this chapter. These safety instructions must always be adhered to during all work on the installation.

All persons performing installation and commissioning work on the FST controller must read this chapter and follow its regulations.

Laws, regulations, guidelines and standards that apply in the country of operation must be followed in addition to the safety regulations mentioned in this manual.

2.1 Qualifications of the installing engineer

The installing engineer must:

- be over 18 years of age (exception: apprentices who are over 16 years of age and are permanently supervised by an engineer qualified for training apprentices).
- have first aid training,
- have theoretical and practical knowledge of regulations and measures for the prevention of fire and explosions in his work area,
- be able to identify, avoid and rectify all dangers that might occur during his work in the shaft and in the operating rooms,
- be able to identify and rectify all irregularities and faults that might occur during installation and operation of a lift systems,
- have theoretical and practical knowledge of operating principles and requirements of electric controls and drive systems.

All installation and commissioning work on electric and electronic components of the FST controller must be performed by or supervised by a qualified electrician.

A qualified electrician has appropriate training and knowledge of regulations that allow him to judge the quality of the work performed and identify possible dangers (DGUV instruction 3).

2.2 Residual dangers

Danger for persons

The following shall always apply during all work on the installation:



Danger to life! Do not touch live parts while working on electrical equipment.

- Before starting work, make sure the system is off circuit.
- Only carry out any installation work on electrical components when these are switched off and in an unpowered state.
- Only use insulated tools when working on electrical system components.



Risk of injury when lifting or moving the control cabinet if it falls down or tips over.

- Only transport and lift the control cabinet with suitable equipment (lift truck, hoisting gear etc.).
- All workers must be trained in using these aids and must observe all applicable special regulations to avoid accidents.



Falling parts or parts protruding into the shaft. Risk of serious injury or death.

- Block the shaft access points.
- Before beginning installation work, remove all foreign parts and assembly aids that are not required from the shaft.



Electrical hazard, leaking gas or water due to pierced supply lines. Risk of serious injury or death.

- Make sure no supply lines are in the installation location before starting any installation work.



Danger of falling! Installing engineers and unauthorized persons can fall down the shaft. Risk of serious injury or death.

- Block the shaft access points.
- Use suitable protection (e.g. safety harnesses, scaffoldings) when working on or in the shaft.



Danger of crushing due to intentional or accidental car movement. Risk of serious injury or death.

- Block the shaft access points.

- Before starting any work, make sure that there are no persons in the shaft or in the vicinity of moving parts of the drive.
- Prevent unauthorized operation of the controller.

Risk of material damage

The following shall always apply during all work on the installation:



Electrostatic charging

- Keep the electronic assembly in its original packaging until installation.
- Before opening the original packaging, a static discharge must be performed. To do this, touch a grounded piece of metal.
- During work on electronic assemblies, periodically perform this discharge procedure.



Electronic assemblies are destroyed by defective, interchanged or incorrectly mounted connectors, short-circuiting or excess voltage.

- Check plugs for mechanical damage.
- Never change pre-assembled connectors or cables.
- Only connect loose or torn off wires according to circuit diagram details if this is possible on site (suitable material and tools must be available).
- Pay attention to coding pins and latch lugs.

2.3 Safety regulations

General

- The instructions of the lift manufacturer and the instructions in this manual must be followed during installation and commissioning of the lift system.
- The shaft must be secured against unauthorized trespassing during installation and commissioning.
- Assemblies, devices and cables must be installed and fastened securely and permanently.
- Loads must be moved with suitable aids (lift trucks, hoisting gear etc.).
- Sharp and pointed tools or other potentially dangerous objects may only be carried along in clothing if suitable protective measures have been taken to rule out any danger.
- Alcohol and drugs must not be consumed before and during installation and commissioning.

Documentation

- A copy of the installation and commissioning manual must be available to the installing engineer at the time of installing and commissioning the FST controller and its components.
- A copy of the installation and commissioning manual and the wiring diagrams must be kept in the control cabinet at all times after.
- The wiring diagrams supplied with the FST controller are binding. Changes must only be made after consulting NEW LIFT and must be documented in writing on the system.
- The factory test logs of the FST controller remain with NEW LIFT.

Electricity

- Regulations for installing and operating electrical equipment (VDE 0100) and regulations of local utilities must be followed.
- The specified distances between different electrical assemblies must be controlled and maintained.
- All installation work must be carried out with the system shut down and off circuit.
- All cables and wires must be installed with sufficient strain relief.
- The neutral and ground wires must be routed separately.
- The control cabinet must be supplied with a clockwise rotary field.

Working in the shaft

- Any work in the shaft requires perfect and permanent communication between the supervisor on the FST controller in the motor room and the workers in the shaft.
- Components in the shaft must be arranged or secured in such a way that persons accessing the shaft for inspection, maintenance or repair purposes are not in danger.
- The maximum load of the lift system must not be exceeded.
- The specified overruns of the emergency end switches in relation to the speed must be observed.
- The emergency installations must not be activated during normal operation.
- All emergency installations and braking systems must be checked for trouble-free operation and all shaft entrances closed off before beginning work.
- Installation and operation are prohibited if other persons could be in danger.
- Workers must be secured against falling.
- In case of any work interruptions, the car must be moved to the lowest stop position, the control system switched off and the power supply (e.g. UPS) permanently disconnected.

Personal safety equipment of the installing engineer

- Eye protection
- Safety boots
- Protective helmet
- Safety harness
- Clothing suitable to the ambient conditions of the installation location
- Jeweler, watches and similar items may not be worn; a hair net must be used if applicable.

Handling electronic assemblies

- Leave electronic assemblies in their original packaging until installation.
- Touch a grounded piece of metal prior to opening the original packaging to prevent damage from static charges.

Waste disposal

- All packaging material must be disposed of in an environmentally acceptable manner; paper, plastic, metal, electronic assemblies etc. must be recycled.

3. Terminals

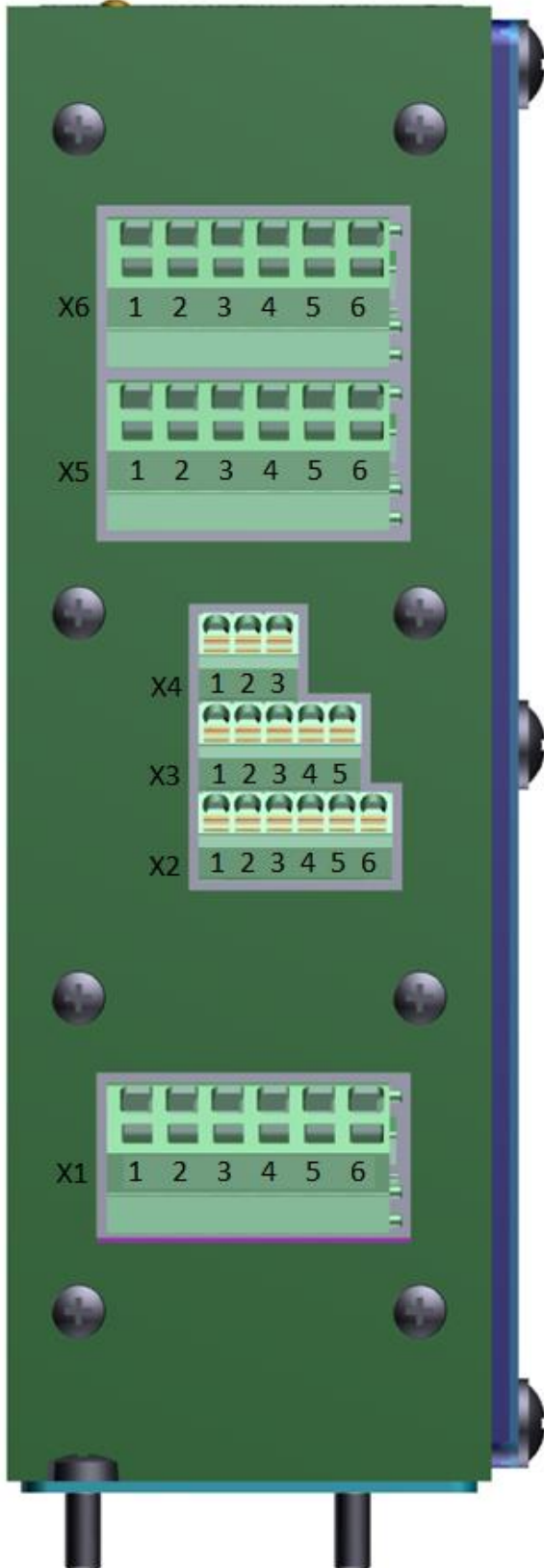

- ← X6: Brake coils
B1+, B1-, B2+, B2-, B3+, B3-

- ← X5: Brake monitoring, Motor-PTC
BM1, BM2, BM3, +24V, PTC, PTC

- ← X4: CAN-Open
GND, CANL, CANH
- ← X3: Outputs
GND, Test, OK, Open, +24V
- ← X2: Inputs
+24V, Brake, T3, T2, T1, Evac

- ← X1: Power, Overvoltage -Test, SHK (Drive)
L, N, OV-Test, OV-Test, Drive, Drive

3.1 Pinout

Clip	Name	Description
X1.1	L	Power Supply – 230VAC
X1.2	N	Power Supply – 230VAC
X1.3	Test	Test Switch to simulate Overvoltage spark
X1.4	Test	Test Switch to simulate Overvoltage spark
X1.5	D	Drive-Signal – 48-230VUC
X1.6	D	Drive-Signal – 48-230VUC
X2.1	+24V	Common pin for inputs on X2
X2.2	Brake	Brake Switch (opens brake)
X2.3	Test 3	Test Switch for Brake 3
X2.4	Test 2	Test Switch for Brake 2
X2.5	Test 1	Test Switch for Brake 1
X2.6	Evac	Evacuation Switch
X3.1	0V	0V – Power Supply for In/Outputs
X3.2	Test	Test active Output (open collector)
X3.3	OK	CBM OK Output (open collector)
X3.4	Open	Brake open Output (open collector)
X3.5	+24V	+24V – Power Supply for In/Outputs
X4.1	GND	GND for CAN
X4.2	CAN-L	CAN-L (CANopen)
X4.3	CAN-H	CAN-H (CANopen)
X5.1	BM1	Brake 1 Monitor Input
X5.2	BM2	Brake 2 Monitor Input
X5.3	BM3	Brake 3 Monitor Input
X5.4	+24V	Common pin for Brake Monitor Inputs
X5.5	PTC	Motor PTC
X5.6	PTC	Motor PTC
X6.1	B1+	Brake 1 Coil +
X6.2	B1-	Brake 1 Coil -
X6.3	B2+	Brake 2 Coil +
X6.4	B2-	Brake 2 Coil -
X6.5	B3+	Brake 3 Coil +
X6.6	B3-	Brake 3 Coil -

4. I/O-Modus

In I/O-Mode the configuration is done by 16 dip switches inside CBM. Controlling is done over the inputs on X2.

4.1 Configuration with dip switches

Inside the housing you can find 2 8-pole dip switches S1 and S2. Following you find the meaning of the individual switches:

S1:

DIP1-3:	Voltage Brake 3		
000	-	AUS	
001	-	40VDC	(max. 160VA)
010	-	80VDC	(max. 240VA)
011	-	120VDC	(max. 240VA)
100	-	160VDC	(max. 240VA)
101	-	200VDC	(max. 240VA)
110	-	reserved	
111	-	Only Brake 2 is connected. Mode for single-circuit brakes!	

DIP4-6:	Voltage Brake 1 and 2		
000	-	AUS	
001	-	40VDC	(max. 160VA)
010	-	80VDC	(max. 240VA)
011	-	120VDC	(max. 240VA)
100	-	160VDC	(max. 240VA)
101	-	200VDC	(max. 240VA)
110	-	reserved	
111	-	reserved	

DIP7-8:	Power Reduction Level %		
00	-	50%	
01	-	62.5%	
10	-	75%	
11	-	87.5%	

S2:

DIP1-2:	Power Reduction Time		
00	-	directly	
01	-	3s	
10	-	5s	
11	-	never	

DIP3-4:	Evacuation Mode		
00	-	3000ms open – 6000ms closed	
01	-	5000ms open – 8000ms closed	
10	-	7000ms open – 10000ms closed	
11	-	permanent open	

DIP5:	Brake Monitoring		
0	-	OFF	
1	-	ON	

DIP6:	Brake Monitoring Contact Type		
0	-	NO	
1	-	NC	

DIP7:	Voltage Ramping		
0	-	slow: 100V/s	
1	-	fast: 200V/s	

DIP8:	Motor PTC Function		
0	-	OFF	
1	-	ON	

4.2 Brake coils with different voltages

By selecting the Power Reduction Time to “directly” and choose a Power Reduction Level, some other voltages can be generated. In that case you must disclaim Power Reduction!

Adjusted Voltage [VDC]	Adjusted Power Reduction	Resulting Voltage [VDC]
200	87.5%	175
200	75%	150
160	87.5%	140
200	62.5%	125
120	87.5%	105
200	50%	100
120	75%	90
120	62.5%	75
80	87.5%	70
80	75%	60
80	62.5%	50

Voltages smaller than 40VDC are not possible. Therefore, power reduction selected with 40VDC will have no effect.

4.3 Explanation of inputs

4.3.1 DRIVE-Signal

The DRIVE-Input can handle voltages from 48-230VUC. As a result, all common safety circuits can be connected here. This signal opens two safety contacts in front of and behind the brake and thus prepares the power supply of the brake coil. If brake coil 3 is connected, which is intended for the transmission of the elevator motor, then this is also opened directly with the DRIVE signal.

4.3.2 BRAKE-Signal

The BRAKE signal opens brake 1 and 2 if both are activated. These two brake coils are mounted on the traction motor.

4.3.3 EVAK-Signal

The EVAK signal is used for evacuation in the event of a fault. It activates a different measurement of the input voltage, since the evacuation can also be carried out with a UPS as power supply. **When the EVAK signal is activated, normal driving is not possible!**

4.3.4 Test-Signal

With the test signals 1-3, either the brake test or the evacuation can be performed.

In addition, by pressing T1 and T2 during the boot process, the EEPROM can be reinitialized with the default values. For details, see section 4.6.

A detailed description of the signal sequences can be found in Section 4.5

4.4 Explanation of Outputs

4.4.1 OK-Signal

The OK output signals that the CBM is active and has no error. This output is only active if both processors (control and monitor CPU) release them.

4.4.2 Open-Signal

The open output signals an open brake.

4.4.3 Test-Signal

The test output signals an active brake test.

4.5 Sequence of the control

4.5.1 Normal ride

During normal driving, only the DRIVE and the BRAKE input are activated. DRIVE must be applied first. In this case, if connected, the brake 3 is opened. Then BRAKE is applied. This opens brake 1 and 2. After the ride BRAKE is deactivated again. Then first brake 1 and 2 close. Thereafter, brake 3 is closed. Now DRIVE must be deactivated again. **The inputs DRIVE and BRAKE are checked with an ABC circuit. This means that DRIVE must be activated before BRAKE and both signals must be deactivated before reactivation!**

4.5.2 Emergency stop

During emergency stop, the DRIVE signal is deactivated first. As a result, all brakes are immediately closed! In this case, no voltage ramp is driven!

4.5.3 Brake test

In the brake test, a normal ride is first initiated. By activating the respective test signal, the corresponding brake is closed immediately. The other brakes remain open. The brake test is signaled directly via the test output to the controller of the lift. This must now ensure that the torque is removed from the frequency converter. As a result, it will disable the BRAKE signal. This is allowed for the brake test. The other brakes remain open anyway. The other brakes only close when the DRIVE signal is deactivated.

4.5.4 Evacuation

To perform an evacuation, the EVAK signal must first be activated. This changes the internal control of the brakes, since the evacuation can also be performed with a UPS. Since it is also possible to use UPSs that do not generate a pure sine wave voltage (VI-SY-333 or better), the phase control must be adjusted. Now the brakes are controlled by the previously stored operating current.

Now the DRIVE signal can be activated. As a result, brake 3 already opens when it is connected. By activating the signals Test 1 and Test 2 the evacuation can be activated. This is carried out in the mode set via the dip switches (pulse and period duration). If you deactivate the signals again, the brakes come back in.

4.6 EEPROM

The EEPROM mainly stores data required for the CANopen functionality. For details, see the CANopen manual.

In addition, the operating currents of the individual brake coils are stored here. These are necessary to perform an evacuation. The default value for all brakes is the equivalent to 0.4A. If this value is still in the EEPROM and a normal ride is triggered, the current values of this normal travel are stored and used in the following. Thus, an evacuation with a CBM in factory settings without prior normal drive would have a current control to 0.4A per brake result. After a single normal ride a correct evacuation is possible!

CANopen-Mode

This chapter will be adapted after integration into the FST control. There is a CANopen manual for integrating the module into a CANopen network.

5. LEDs

5.1 Voltage setting

The set voltage of each brake can be read via 3 LEDs each. Their meaning is the same with the voltage set via the dip switches S1.1-6!

Table 1 - LEDs for Brake 1/2

○ ○ ○	Deactivated
○ ○ ●	40VDC
○ ● ○	80VDC
○ ● ●	120VDC
● ○ ○	160VDC
● ○ ●	200VDC
● ● ○	Deactivated
● ● ●	Deactivated

Table 2 - LEDs for Brake 3

○ ○ ○	Deactivated
○ ○ ●	40VDC
○ ● ○	80VDC
○ ● ●	120VDC
● ○ ○	160VDC
● ○ ●	200VDC
● ● ○	Deactivated
● ● ●	Only Brake 2 connected (single-circuit brake)

5.2 Status-LEDs

Each of the two integrated controllers has a 2-color LED (blue / red). The meaning of the states is different.

5.2.1 Status Monitoring

Blue LED:

- On: Monitoring OK
- Off: Monitoring not OK

Red LED:

The red LED indicates a fault condition. It can show a 5-digit error code by flashing. The duration of a job is 1000ms. A logical 1 has an on time of 500ms while a logical 0 only has an on time of 100ms. To find the beginning of the 5-digit code, there is a break of 2000ms between the end and the beginning.

Fehler	B0	B1	B2	B3	B4	Beschreibung
0x00	0	0	0	0	0	No Error
0x01	1	0	0	0	0	Inputs during booting not in initial position
0x02	0	1	0	0	0	ABC Error of inputs DRIVE and BRAKE
0x03	1	1	0	0	0	Internal DRIVE signals are not the same
0x04	0	0	1	0	0	BRAKE signal active before DRIVE signal
0x05	1	0	1	0	0	Trigger-Signal from Monitor-CPU not detected
0x06	0	1	1	0	0	Short-circuit tests of MOSFETs in MAIN-CPU unsuccessful

5.2.2 Status Controlling

Blue LED:

- On: Controlling OK
- Flashing with 400ms/1000ms: Brake open
- Flashing with 100ms/1000ms: Evacuation active
- Off: Controlling not OK

Red LED:

The red LED indicates a fault condition. It can show a 5-digit error code by flashing. The duration of a job is 1000ms. A logical 1 has an on time of 500ms while a logical 0 only has an on time of 100ms. To find the beginning of the 5-digit code, there is a break of 2000ms between the end and the beginning.

Error	B0	B1	B2	B3	B4	Description
0x00	0	0	0	0	0	No Error
0x01	1	0	0	0	0	Inputs during booting not in initial position
0x02	0	1	0	0	0	ABC Error of inputs DRIVE and BRAKE
0x03	1	1	0	0	0	Internal DRIVE signals are not the same
0x04	0	0	1	0	0	BRAKE signal active before DRIVE signal
0x05	1	0	1	0	0	Trigger-Signal from Monitor-CPU not detected
0x06	0	1	1	0	0	Overtemperature (>85°C) on PCB
0x07	1	1	1	0	0	Overtemperature in Motor
0x08	0	0	0	1	0	Overcurrent in brake circuit 1
0x09	1	0	0	1	0	Overcurrent in brake circuit 2
0x0A	0	1	0	1	0	Overcurrent in brake circuit 3
0x0B	1	1	0	1	0	Undercurrent in brake circuit 1
0x0C	0	0	1	1	0	Undercurrent in brake circuit 2
0x0D	1	0	1	1	0	Undercurrent in brake circuit 3
0x0E	0	1	1	1	0	Error in Thyristor in brake circuit 1
0x0F	1	1	1	1	0	Error in High-Side-MosFET in brake circuit 1
0x10	0	0	0	0	1	Error in High-Side-MosFET in brake circuit 1
0x11	1	0	0	0	1	Error in Thyristor in brake circuit 2
0x12	0	1	0	0	1	Error in High-Side-MosFET in brake circuit 2
0x13	1	1	0	0	1	Error in High-Side-MosFET in brake circuit 2
0x14	0	0	1	0	1	Error in Thyristor in brake circuit 3
0x15	1	0	1	0	1	Error in High-Side-MosFET in brake circuit 3
0x16	0	1	1	0	1	Error in High-Side-MosFET in brake circuit 3
0x17	1	1	1	0	1	Internal 12V power supply faulty
0x18	0	0	0	1	1	Diagnostic inputs incorrect during boot process

0x19	1	0	0	1	1	Brake monitoring faulty
0x1A	0	1	0	1	1	Diagnostic-Error

6. Technical data

Description	Value
Supply Voltage	230V AC $\pm 5\%$
Typical power consumption	Brake inactive – 160mA (with active brakes depending on connected brakes)
Internal Fuse	5A T – 1500A safe switch off capability
Temperature range	Storage: -20 - +70°C Operation: 0 - +60°C
Relative humidity (not condensing)	Storage/Transport: +5 - +95% Operation: +15 - +85%
Length x width x depth	319mm x 59mm x 167mm
Mass	2600g