

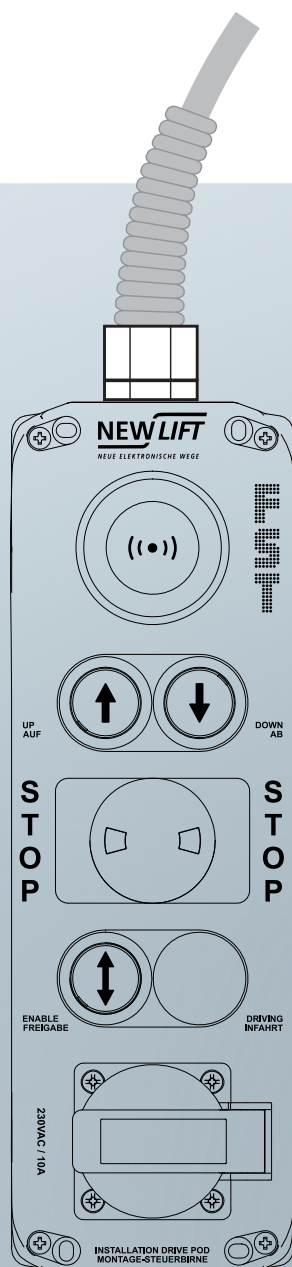

Installation drive pod V2



Manufacturer NEW *LIFT* Neue elektronische Wege
Steuerungsbau GmbH
Lochhamer Schlag 8
82166 Gräfelfing
Tel +49 89 - 898 66 - 0
Fax +49 89 - 898 66 - 300
Mail info@newlift.de
www.newlift.de

Service line Tel +49 89 - 898 66 - 110
Mail service@newlift.de

Date of issue 28.11.2013

Author AL / EP

Last Change 28.03.2024 AME

Release 28.03.2024 AL

Hardware version 2.6

Doc. No. hb_MSB2_2024-03_en

Copyright © NEW *LIFT* Steuerungsbau GmbH, 2024.

This manual is protected by copyright. All rights, including those of copying, of reproduction, of translation and of modification, in whole or in part, are reserved by the publisher.

No part of this description may be reproduced in any form or copied with an electronic replication system without written permission.

Although great care has been taken in the production of texts and figures, we cannot be held legally liable for possible mistakes and their consequences.



Inhalt

1	General	4
1.1	Abbreviations, characters and symbols used	4
1.2	Notation	4
1.3	Further information	5
1.4	How to contact us	5
2	Safety	6
2.1	General safety regulations	6
2.2	General	6
2.3	Working in the shaft	6
2.4	Personal safety equipment of the installing engineer	6
3	Installation drive pod MSB 2	7
3.1	Construction and function	7
3.2	Connection	8
3.2.1	Connecting the MSB 2 to the FST-2XT	8
3.2.2	Connecting the MSB 2 to the FST-2XT	9
3.2.3	Connecting the MSB 2 to the FST-3 (FST-3 adapter set)	10
3.3	Using the MSB 2	11
3.4	Circuit Diagram	12

1 General

The Installation Drive Pod MSB 2 allows the unfinished car platform to be used for installation work, using dead-man drive controls without requiring a trailing cable, a car top-box or an inspection control pod.

1.1 Abbreviations, characters and symbols used

Symbol / abbreviation	Meaning
MSB 2	Installation control pod
	Warning notice This symbol is located in front of safety-relevant information
	Information notice This symbol is located in front of relevant information.
	Operational instructions Perform the tasks that follow this symbol in the specified order.
•	Action step under the respective operational instruction

1.2 Notation

Notation	Meaning
Bold	› Designations of switches and actuators › Input values
<i>Italics</i>	› Captions › Cross references › Designations of functions and signals › Product names
<i>Bold italics</i>	› Remarks
LCD font	› System messages of the controller

1.3 Further information

The following documents, among others, are available for the FST-2 controller and its components:

- › FST-2 Installation & Commissioning Manual
- › FST-2 manual
- › ADM manual
- › FPM manual
- › SAM manual
- › Fire recall manual

These and other current manuals can be found in the download area of our website at

<https://www.newlift.de/downloads-311.html>

1.4 How to contact us

If, after referring to this manual, you still require assistance, our service line is there for you:

Phone	+49 89 - 898 66 - 110
E-mail	service@newlift.de
Mon. - Thurs.:	8:00 a.m. - 12:00 p.m. and 1:00 p.m. - 5:00 p.m.
Fr:	8:00 a.m. - 3:00 p.m.

2 Safety

2.1 General safety regulations

The Installation Drive Pod must only be operated in perfect working condition in a proper manner, safely and in compliance with the manual, the valid accident prevention regulations and the guidelines of the local power company.



This manual is a supplement to the FST manual and the FST Installation and Commissioning manual whose safety guidelines must always be observed.

2.2 General

- › The instructions of the lift manufacturer and the instructions in this manual must be followed during installation and commissioning of the safety device.
- › The shaft must be secured against unauthorised trespassing during installation, commissioning, inspection and maintenance.
- › Assemblies, devices and cables must be installed and fastened securely and permanently.
- › Loads must be moved with suitable aids (lift trucks, hoisting gear etc.).
- › Sharp and pointed tools or other potentially dangerous objects may only be carried along in clothing if suitable protective measures have been taken to rule out any danger.
- › Alcohol and drugs must not be consumed before and during installation and commissioning.

2.3 Working in the shaft

- › Any work in the shaft requires perfect and permanent communication between the supervisor on the lift controller and the workers on the FST-2/3 in the shaft.
- › Components in the shaft must be arranged or secured in such a way that persons accessing the shaft for inspection, maintenance or repair purposes are not in danger.
- › The maximum load of the lift system must not be exceeded.
- › The specified overruns of the emergency end switches in relation to the speed must be observed.
- › The emergency installations must not be activated during normal operation.
- › All emergency installations and braking systems must be checked for trouble-free operation and all shaft entrances closed off before beginning work.
- › Installation and operation are prohibited if other persons could be in danger.
- › Workers must be secured against falling.
- › In case of any work interruptions, the car must be moved to the lowest stop position, the control system switched off and the power supply (e.g. UPS) permanently disconnected.

2.4 Personal safety equipment of the installing engineer

- › Eye protection
- › Safety boots
- › Protective helmet
- › Safety harness
- › Clothing suitable to the ambient conditions of the installation location
- › Jewellery, watches and similar items may not be worn; a hair net must be used if applicable.

3 Installation drive pod MSB 2

3.1 Construction and function

The Installation Drive Pod MSB 2 is supplied with a 30m long trailing-cable, pre-wired with the FST connectors X2, X14, X18, X19, X31, and X32.

The Installation Drive Pod MSB 2 has the following controls:

- › a red emergency stop button marked “Stop / Nothalt”
- › an audible alarm to warn when the emergency stop button is not activated
- › a white drive button marked “Up / Auf”
- › a black drive button marked “Down / Ab”
- › an blue enable button marked “Enable / Freigabe
- › a yellow control lamp marked “Driving / In Fahrt”
- › a mains socket rated 10A/230V, IP54

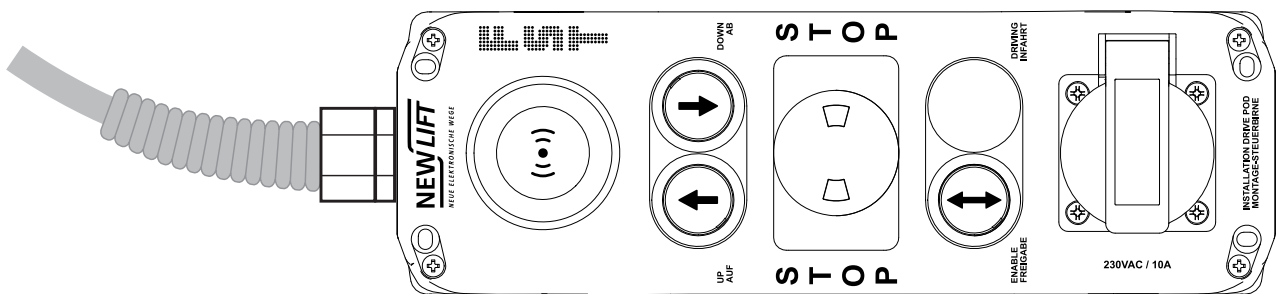

Installation drive pod

The MSB 2 allows the lift engineer to drive a platform lift in dead-man using dead-man controls, without requiring the lift's trailing-cable, car top-box or inspection control pod. All necessary safety circuit bridges to allow dead-man operation are handled by the MSB 2!

3.2 Connection



Ensure that the MSB's 2 trailing cable is adequately supported with strain relief mountings in the shaft. The trailing-cable must not, under any circumstances, be allowed to become trapped, squashed or damaged by the platform.



Isolate power completely to the installation before making any wiring changes to the Installation Drive Pod MSB 2.

3.2.1 Connecting the MSB 2 to the FST-2XT

- Plug the connectors **X2**, **X14**, **X18**, **X19** and **X32** from the MSB 2 trailing-cable into the respective sockets on the FST-2 and **X31** into the terminal block in the control cabinet, as shown in figure.

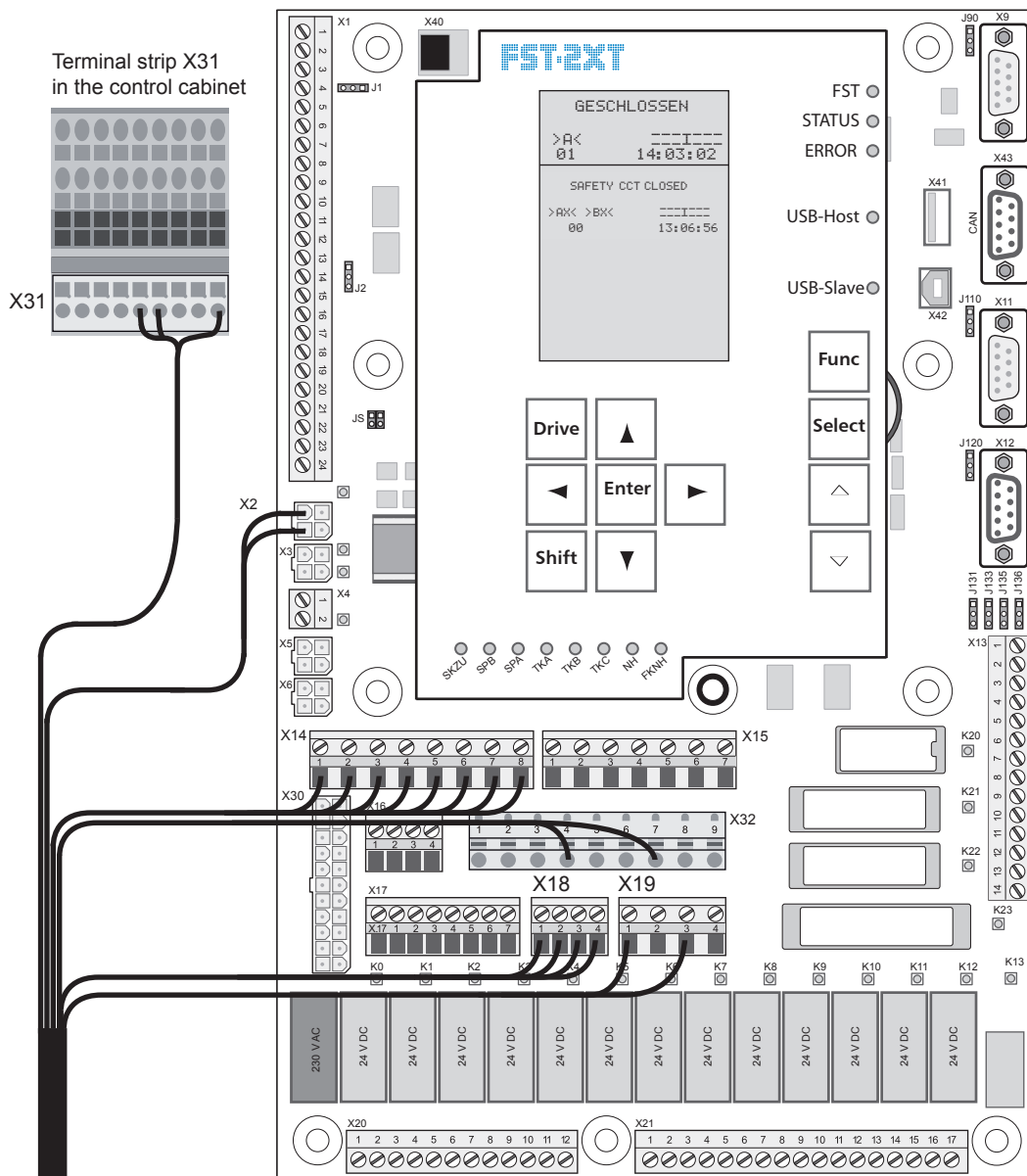

Connecting the MSB 2

3.2.2 Connecting the MSB 2 to the FST-2XT

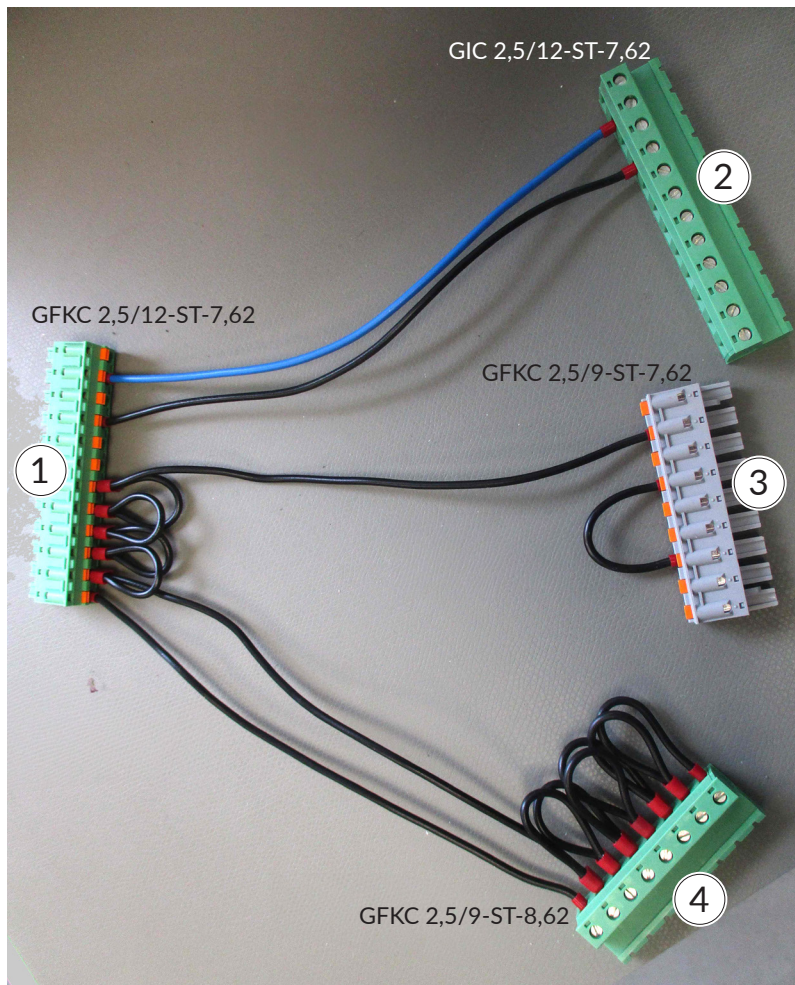

FST-2XTs MSB 2 Adapter set

- ▶ Unplug the connector strip **X14** from the FST-2XTs and plug it into the socket (2).
- ▶ Connect plug (1) to the FST-2XTs **X14**.
- ▶ Connect plug (3) to socket **X32** on the FST-2XTs, do not connect plug **X32** from the MSB 2.
- ▶ Connect socket (4) to the same-pole plug of the MSB 2.
- ▶ Connect **X18**, **X19** and **X31** in the same way as for the FST-2XT.
The 4-pin bus connector (white) can also be connected to **X3**.

3.2.3 Connecting the MSB 2 to the FST-3 (FST-3 adapter set)



When using an “electromagnetic safety gear” (ESG or similar), additional safety measures are required during installation!

► Follow the instructions in the installation, commissioning and testing instructions (MIPA) for the FST-3!

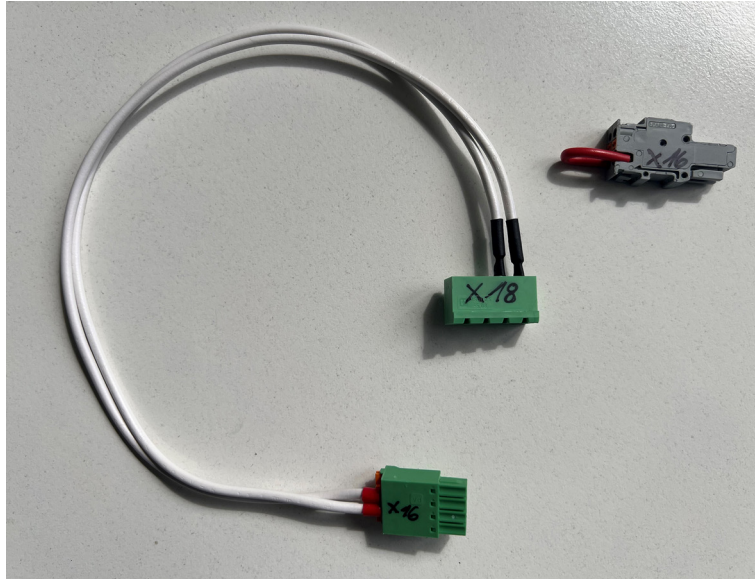

FST-3 MSB 2 Adapter set

- Switch off the FST and S2 control unit by switching off **F4** and **F50**.
- Disconnect plugs **X14** and **X16** from the S2.
- Connect the adapter cable to the S2/**X16**.
- Connect **X18** socket of the adapter cable to the 4-pin plug of the MSB 2.
- Connect the plug of the MSB 2 to **X31** (terminal strip switch cabinet) **X32**, **X14** (S2) and **X2** (FST-3).
- Connect the 2-pole plug to terminal strip **X14** in the control cabinet, to terminals 1 and 2.



Reconnect pre-wired plugs for final commissioning!

- if not already present:
Set temporary wire jumpers at the following terminals:
 - X50:2 and 12
 - X50:3 and 13
 - X50:4 and 14
 - X50:5 and 15
 - X50:6 and 16
 - X50:7 and 17
 - X50:8 and 18.
- Remove temporary bridges after the installation run!
See also the system wiring diagram.
- If GB drop-out protection is present, the feedback contact must be connected or bridged:
To do this, connect a jumper to terminals X40:95 and 96.



Remove temporary bridges after the installation run and adjust the connection according to the elevator conditions! See system wiring diagram.

- Switch on the **FST** control unit and **S2**.
If the S2 displays an error (e.g. S2 error or similar)
Perform an error reset.

- Switch the return control **ON**
- Select S2 reset in the test menu
- Switch the return control **OFF** within 15 seconds.

3.3 Using the MSB 2



The red „Stop / Not-Halt“ emergency stop button opens the safety circuit and must be activated following every drive! The audible alarm will sound when the emergency stop button is not activated!

If the emergency stop button is not activated, the platform is not protected against uncontrolled movement due to an electrical or operating error!

Before beginning every work shift, test the emergency stop button „Stop / Not-Halt“ to ensure faultless operation. The following tests are necessary:

- › After activating the „Stop / Not-Halt“ emergency stop button, „EMERGENCY STOP“ should be displayed in FST-2's LCD Line-A.
- › After activating the „Stop / Not-Halt“ emergency stop button, it should not be possible to drive the platform using the „Up /Auf“ or „Down /Ab“ buttons.
- › Activating the „Stop / Not-Halt“ emergency stop button during a drive, should bring the platform to an immediate stop, without discernible controlled deceleration.
- › When the emergency stop button is not activated, the audible alarm should sound.



If the audible alarm does not sound, or any other function of the „Stop / Not-Halt“ emergency stop button does not function exactly as described above, the Installation Drive Pod MSB 2 may not be used!

Required conditions before making the first drive

- › the Installation Drive Pod MSB 2 is connected electrically
- › the drive system is operating correctly
- › the FST-2 is operating in Installation Mode (CONFIGURATION /INSTALLATION /INSTALLATION MODE = ON)
- › the operation of the „Stop / Not-Halt“ emergency stop button has been tested

Required conditions before every drive

- › make sure that no persons are present in the shaft that might be endangered by the driving of the platform!
- › test the functioning of the „Stop / Not-Halt“ emergency stop button
- › before stepping onto the platform, make sure that the drive direction and drive speed are correct:
 - »when driving upwards, the platform must drive in a upwards direction
 - »when driving downwards, the platform must drive in a downwards direction
 - »the drive speed of the platform must not exceed 0.6m/s in both directions!

Driving in an upwards or downwards direction

- › deactivate the „Stop / Not-Halt“ emergency stop button by pulling out
 - ↳ the audible alarm turns on
- › press the „Up /Auf“ or „Down /Ab“ drive button together with the „Enable, Freigabe“ button
 - ↳ the platform starts to move and the „Driving / in Fahrt“ control lamp illuminates
- › end the drive by releasing both buttons and activate the „Stop / Not-Halt“ emergency stop button immediately.
 - ↳ the audible alarm turns off

3.4 Circuit Diagram

3.4.1 MSB 2 for FST-2XT

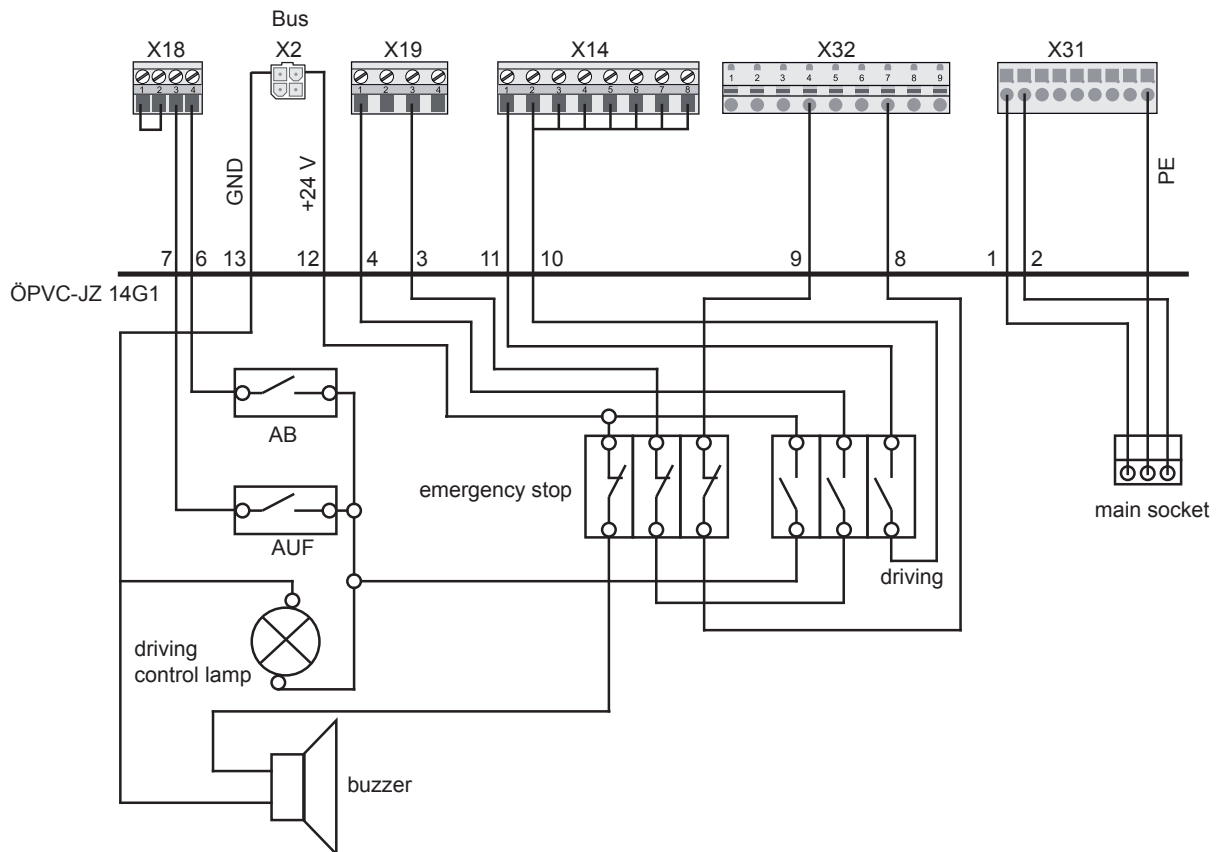

MSB 2 circuit diagramm

3.4.2 MSB 2 for FST-3

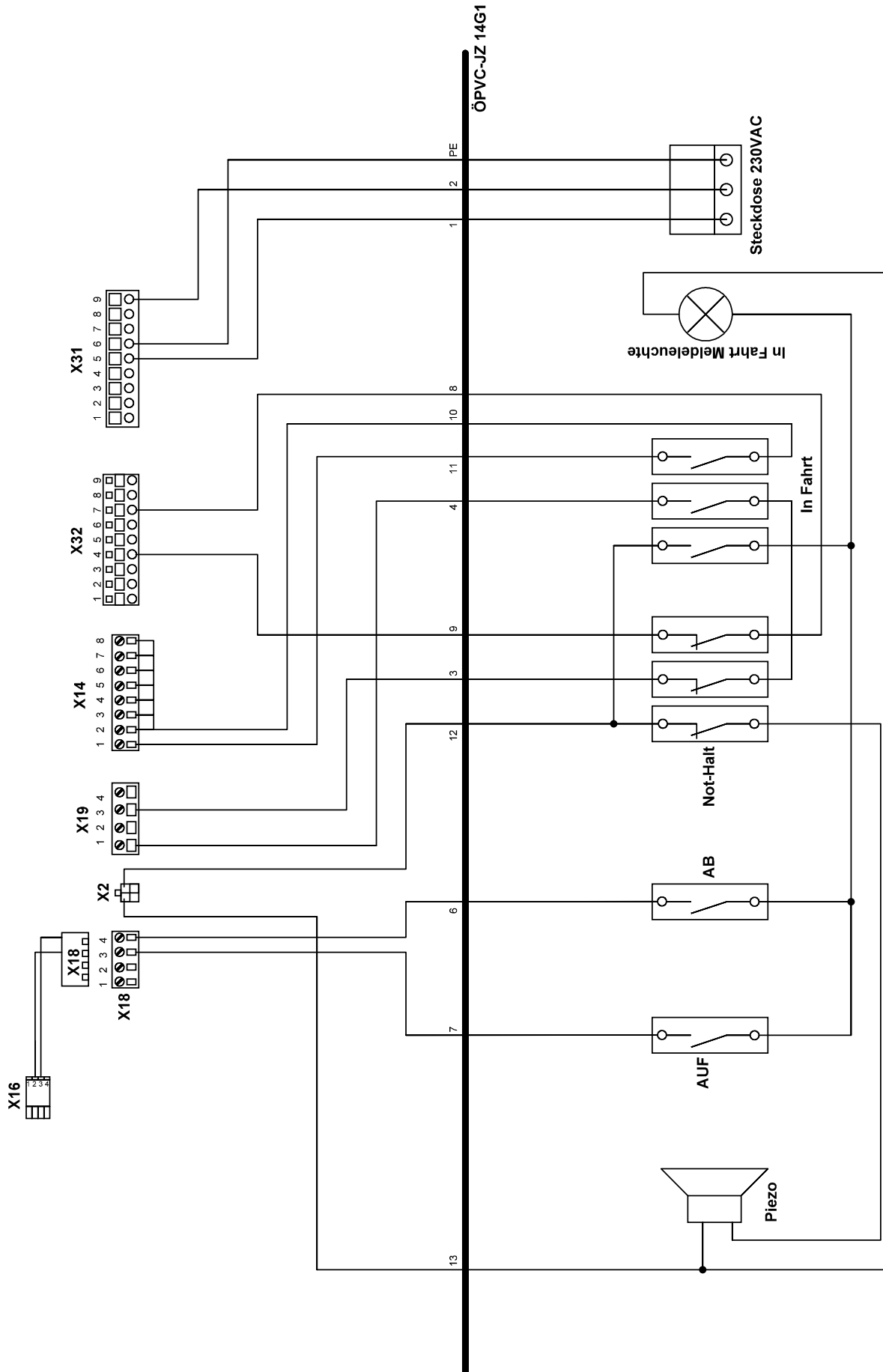

📍 **NEW LIFT** Neue Elektronische Wege

Steuerungsbau GmbH
Lochhamer Schlag 8
DE 82166 Gräfelfing

☎ +49 (0) 89 898 66 0
📠 +49 (0) 89 898 66 300
✉ info@newlift.de
🌐 www.newlift.de

📍 **NEW LIFT**

Service Center GmbH
Ruwerstraße 16
DE 54427 Kell am See

☎ +49 (0) 6589 919 540
📠 +49 (0) 6589 919 540 300
✉ info@newlift-sc.de
🌐 www.newlift.de